



- 
- Robust Bottle Filler and Drinking Fountain
  - Reduce Waste of Single-use Plastic Bottles
  - Pre-Plumbed Non-Chilled
  - Ideal for Schools and Public Amenities
  - Smooth Radiused Design
  - Grade 304 Satin Stainless Steel
  - Hygienic Vandal Resistant Design
  - Suitable for use with 0.5, 0.75 and 1 litre bottles

This floor standing stainless steel drinking fountain and bottle filling station features both a traditional drinking water bubbler valve and separate a bottle filling station with a button operated flow valve. The semi circular design eliminates sharp corners which reduces the likelihood of injury to the user. The unit is pre-plumbed with an appropriate water inlet hose. Each function has separate water traps and waste pipes which join to form a single waste from the unit.

This sturdy robust stainless steel drinking fountain will not deteriorate if installed outside but will need to be isolated and drained down during periods of freezing weather. As a further precaution it is recommended to dismount the fountain and store it in an area where temperatures will not fall below freezing.

### Sample specification Text

Stainless Steel Non-Chilled Floor Standing Bottle Filling Station with Combined Drinking Fountain - 330mm (W) x 365mm (D) **900mm** Adult or **760mm** Junior (H) Supplied Pre-Plumbed - Product Code **GW-951** Adult, or **GW952** Junior

\***RED TEXT** may denote a variable

# BOTTLE FILLING STATION WITH COMBINED DRINKING FOUNTAIN

MODEL  
GW-951

# Gentworks

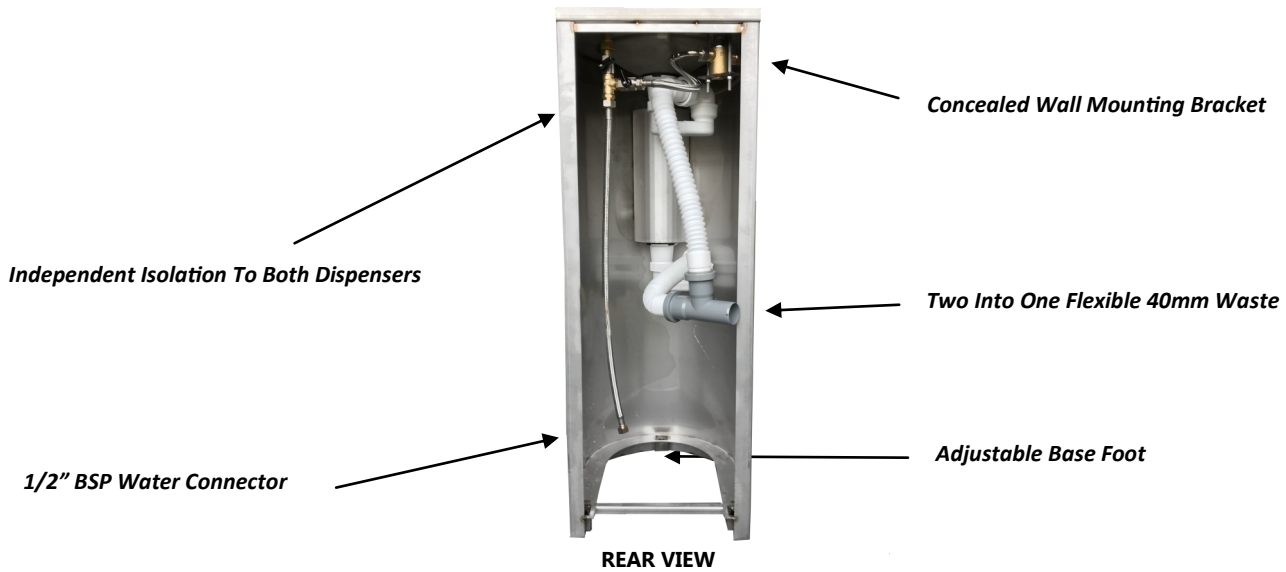
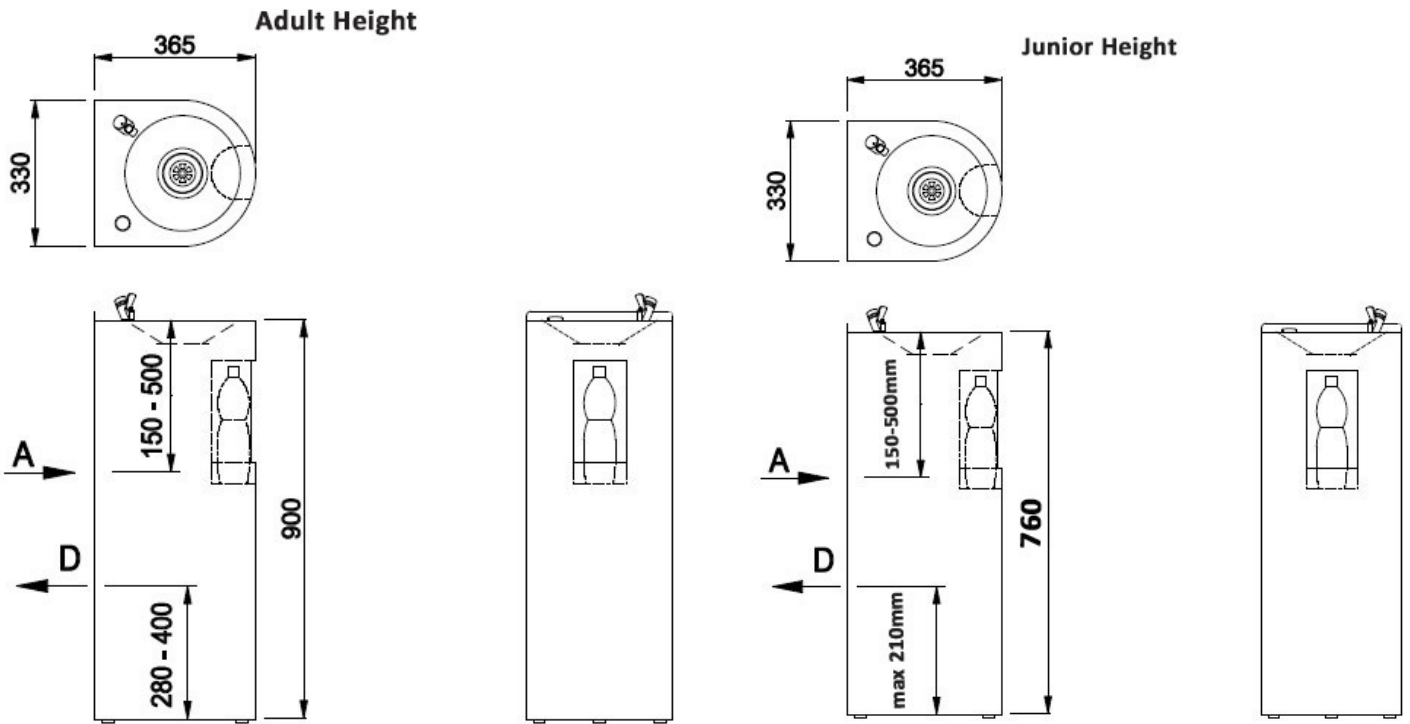

## OPTIONAL ITEMS



**DF-RAIL-PRV**

Mains Water Installation Rail— prevents backflow and maximum pressure from being exceeded.



**Gentworks**

The Barn, Emmington, OX39 4AA | [www.gentworks.co.uk](http://www.gentworks.co.uk) | [sales@gentworks.co.uk](mailto:sales@gentworks.co.uk) | Ph. +44(0)1844 353210